



SPC FLOORING

CATALOG



Vietnam Value



THE ONLY manufacturer in Vietnam

That owns limestone quarries and is self-sufficient in high-quality CaCO_3 (Calcium Carbonate) powder for the production of SPC flooring

PRODUCTION CAPACITY

TOP VIETNAMESE OEM MANUFACTURER

02 FACTORIES

NEO FLOOR's current infrastructure is capable of growing up to 40+ extrusion lines for SPC, LVT, and WPC products, supporting 1,000 containers for our US based partners. Our plan for 2027 is to further strengthen our infrastructure, with the ability to expand to over 42 extrusion lines, achieving a target capacity of 45 million sqm per year.





PRODUCT ECOSYSTEM



SINGLE LAYER SPC FLOORING

SPC, which stands for Stone Plastic Composite, features a core comprising of calcium carbonate (limestone), in addition to polyvinyl chloride (PVC). SPC is the most highly-demanded product in the flooring market - overcoming disadvantages and replaces traditional products such as traditional glue-down LVT flooring, hardwood flooring, and laminate flooring, etc. Key features include: Phthalate-free, 100% waterproof, flame retardant, anti-slip, anti-scratch, no warping and shrinking, and easy installation.

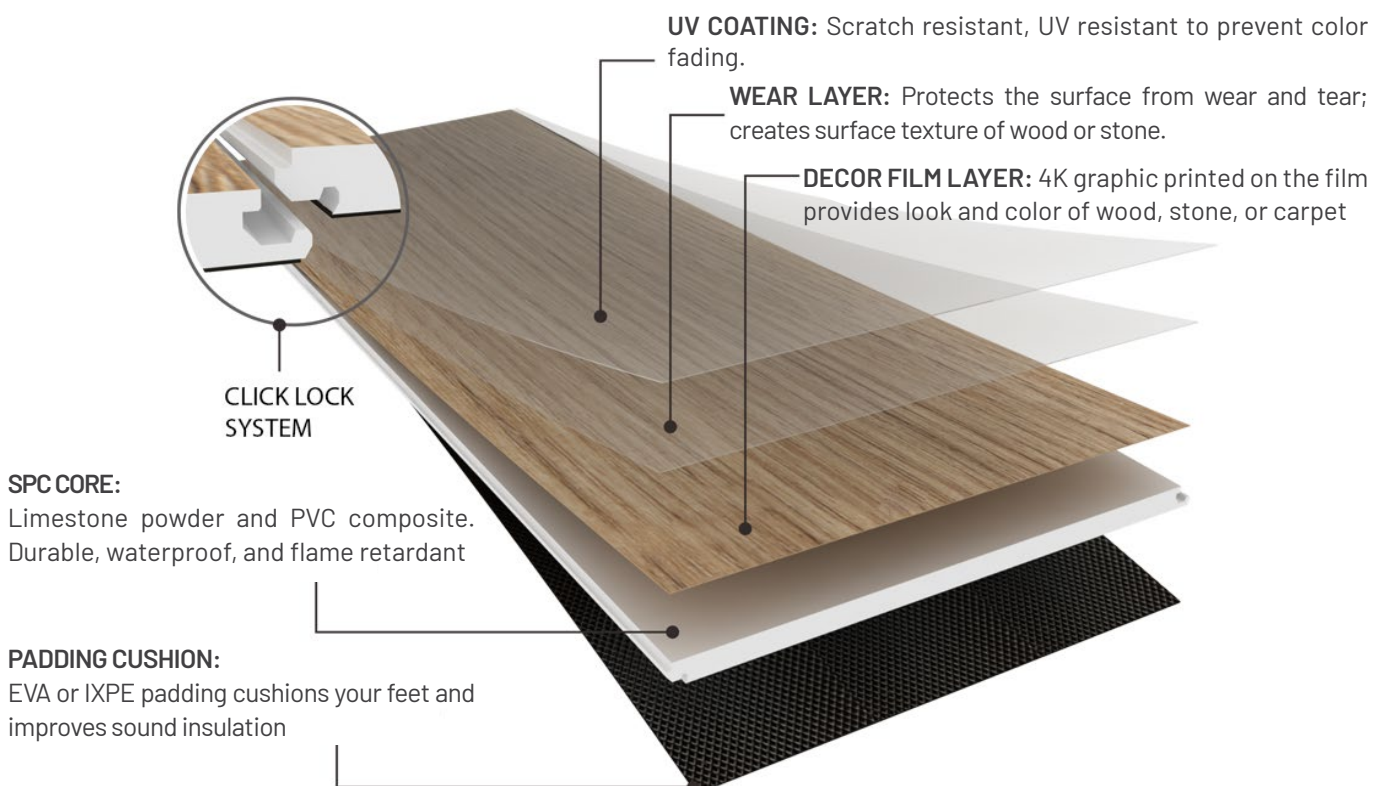

SPC HERRINGBONE

Maintaining all the SPC flooring benefits, SPC Herringbone flooring offers a new look for your home, creating a zig zag pattern inspired by the spinal bone of the herring fish. It is a timeless choice of flooring that can accommodate both modern and classic style interiors.



CO-EXTRUSION SPC FLOORING

Co-extrusion (ABA) construction, takes SPC flooring to a next level. The two extra supporting SPC core layers help to improve dimensional stability significantly, along with better foot comfort, and sound insulation. Customers will also benefit from the more aesthetic look of the core layer and ultra-real EIR surface finishes.

DECOR FILM:

HD graphic printed on the film provides look and color of wood, stone, or carpet.

REINFORCED RIGID VINYL LAYER:

Provides extra support and stability for the core layer.

CORE LAYER:

Limestone powder and PVC composite. Durable, waterproof, and fire retardant.

REINFORCED RIGID VINYL LAYER:

provides extra support and stability for the core layer.

PADDING: EVA or IXPE padding cushions your feet and improves sound insulation.

WEAR LAYER:

Protects the surface from wear and tear; embossed (in register) to create texture of wood or stone

URETHANE UV COATING:

(with aluminum oxide or ceramic beads as optional), provides scratch, stain, fade resistance.

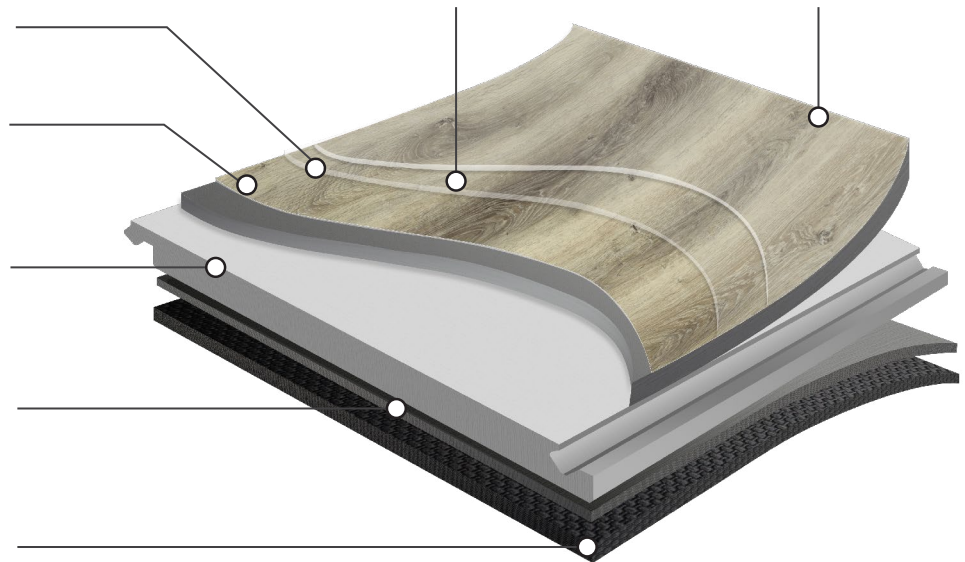



LIGHT SPC FLOORING

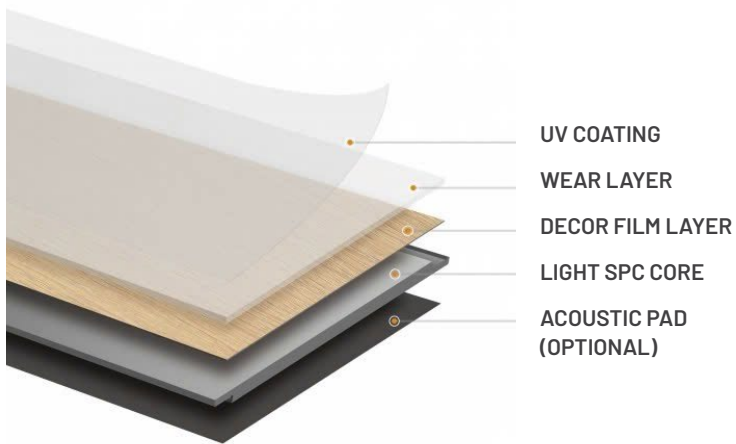

- UV COATING
- WEAR LAYER
- DECOR FILM LAYER
- LIGHT SPC CORE
- ACOUSTIC PAD (OPTIONAL)

Light SPC is a groundbreaking concept that redefines sustainability in the flooring industry. The foamed core material with micro cells meets indentation resistance standards, ensuring dimensional stability and long-lasting performance. At its core, Light SPC is a lightweight, environmentally conscious flooring material that delivers a multitude of benefits, both in terms of production efficiency and environmental impact.

- Up to 20% lighter
- Optimized transportation
- Efficient production
- Impact insulation class (IIC), better than other types of flooring



WPC FLOORING

WPC (Wood Plastic Composite) - a mixture of plastic and Foam agent, creating a waterproof core. NEO FLOOR's WPC core is reinforced with foaming agents, making it slightly softer and more comfortable in addition to its complete waterproof capability.

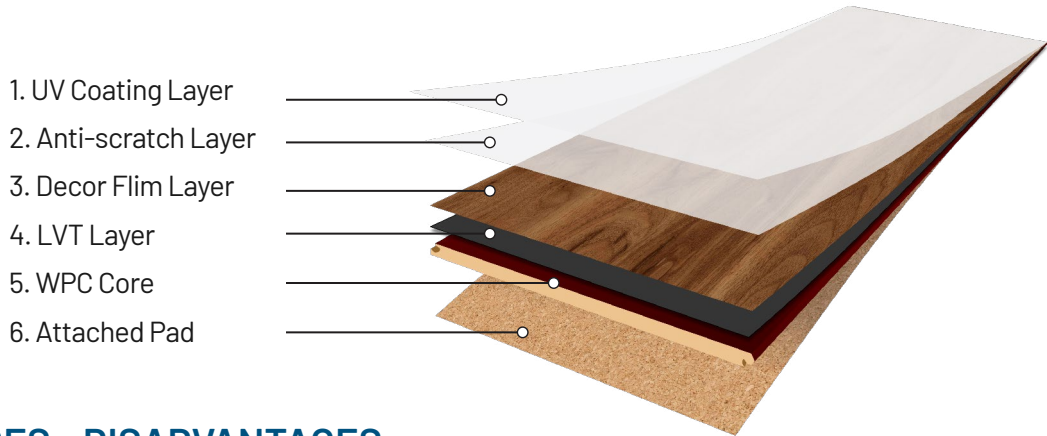

ADVANTAGES - DISADVANTAGES:

- Aesthetic appearance similar to natural wood
- Good sound absorption, limiting noise when moving on the floor
- Lighter, offering a softer and more comfortable feel compared to other types of flooring
- Offers the advantages of PVC flooring: 100% water resistance, fire resistance, easy to install

LVT FLOORING

LVT (Luxury Vinyl Tile) is a modern adhesive vinyl flooring. Made by mixing and melting polyvinyl chloride (PVC), calcium carbonate powder, plasticizers, PU coatings and additives, LVT flooring brings luxury and diversity to every interior space. LVT flooring offers a softer feel and a variety of design patterns. It is also a cost-effective choice and can be easily installed in different environments.

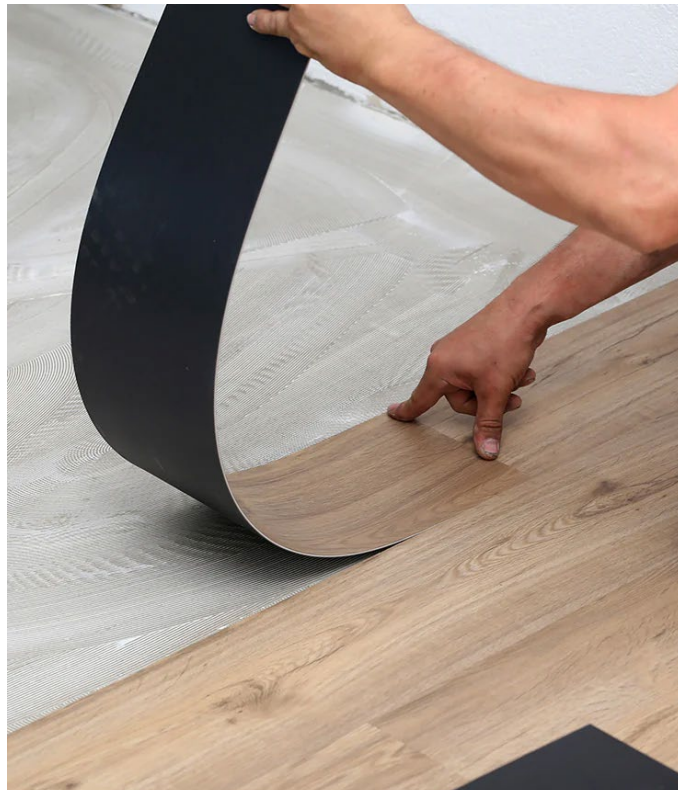

SUPER MATTE FINISH

NEO FLOOR flooring products are designed to enhance your living space with a stunning Super Matte Finish (GU 2.2 - 3.0) that offers the perfect combination of style and practicality.



LOCKING MECHANISM

We use patented locking systems provided by the top leading locking technology developers in the flooring industry - Unilin and I4F.

TYPE OF LOCKING SYSTEM



SPC VINYL FLOORING

no glue required

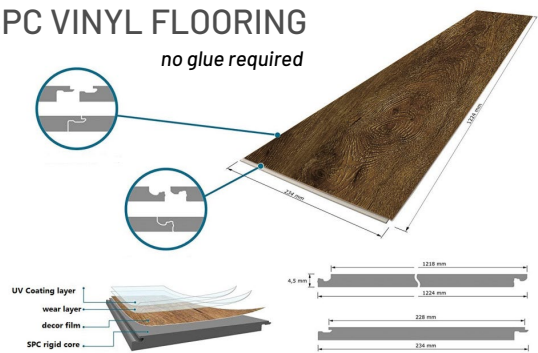

TECHNICAL DATASHEET *NORMAL SPC FLOORING*

CHARACTERISTICS		METHODS	TEST RESULTS
Floorscore			Certified
Greenguard Gold			Certified
CE			Certified
Phthalate Content			Not Detected
Fire Resistance and Smoke Emission			Class Bfl s1
Slip Resistance		EN 13893	Class DS
Dimension Stability		ISO 23999/ ASTM F2199	≤0.1%
Static Loading		ASTM F970/ ASTM F387	Residential : N/A Commercial : ≤0.13 mm
Scratch Resistance		EN 16094	B3, B2, B1
Castor Chair		EN 425	Class 31 (EN ISO 10874) ≥ 10,000 cycles Class 32, 33, 34 (EN ISO 10874) ≥ 25,000 cycles
Impact sound insulation class (IIC)		ASTM E492-09(2016)	With Pading and Ceiling : 56 - 78
Sound transmission class (STC)		ASTM E90-09	With Pading and Ceiling : 55 - 76
Resistance to heat		ASTM F1514	ΔE ≤ 8
Resistance to light		ASTM F1515	ΔE ≤ 8
VOC Emission		BS ISO 16000 / ASTM D5116	Certified
Formaldehyde emission		EN 717-1	E1
Heavy metal		ASTM F963	Not Detected
Suitable for Underfloor Heating			Yes, max. 80°F (27°C)

TECHNICAL DATASHEET *ABA SPC FLOORING*

CHARACTERISTICS	METHODS	TEST RESULTS
Floorscore 		Certified
Greenguard Gold 		Certified
CE 		Certified
Phthalate Content 		Not Detected
Fire Resistance and Smoke Emission 	EN 13501-1	Class Bfl s1
Slip Resistance 	EN 13893	Class DS
Dimension Stability 	ISO 23999/ ASTM F2199	≤0.08 %
Static Loading 	ASTM F970/ ASTM F387	Residential : N/A Commercial : ≤0.13 mm
Scratch Resistance 	EN 16094	B2 , B1
Castor Chair 	EN 425	"Class 31 (EN ISO 10874) ≥ 12,000 cycles Class 32, 33, 34 (EN ISO 10874) ≥ 25,000 cycles"
Impact sound insulation class (IIC) 	ASTM E492-09(2016)	With Pading and Ceiling : 56 - 78
Sound tranmission class (STC) 	ASTM E90-09	With Pading and Ceiling : 55 - 76
Resistance to heat 	ASTM F1514	ΔE ≤ 8
Resistance to light 	ASTM F1515	ΔE ≤ 8
VOC Emission 	BS ISO 16000 / ASTM D5116	Certified
Formaldehyde emission 	EN 717-1	E1
Heavy metal 	ASTM F963	Not Detected
Suitable for Underfloor Heating 		Yes, max. 82°F(28°C)

SIZE VARIETY

S01	48"x7" (1220x182mm)	S07	24"x12" (610x305mm)
S02	48"x9" (1220x230mm)	S08	48"x7" (1220x183mm)
S03	60"x9" (1524x230mm)	S09	60"x7" (1524x182mm)
S04	36"x6" (915x152mm)	S10	60"x9" (1520x228mm)
S05	48"x7" (1220x181mm)	S11	24"x5" (610x128mm)
S06	60"x9" (1530x228mm)	S12	60"x9" (1514x230mm)

UNDERLAYMENT

Padding classification	IXPE			CORK	EVA
Thickness	Density 7.5	Density 10	Density 15		
1.00 mm	●	●	●	●	●
1.50 mm			●	●	●
2.00 mm			●	●	●

Pictures   

SURFACE FINISHING



TYPES OF BEVELS



CERTIFICATE



ISO 9001:2015
International quality management system standards



FLOOR SCORE
Indoor air quality standards



CE
European quality standards



GREENGUARD GOLD
Certified Low Chemical Emissions



SMETA
Audited responsible supply chains



C-TPAT
Audited customs trade partnership against terrorism



OUTSTANDING FEATURES

As the latest high-end product, SPC flooring possesses outstanding performance qualities, overcoming all disadvantages of traditional flooring materials.



DURABILITY OVER 15 YEARS

100% virgin materials are used to produce SPC flooring, which makes quality stable on every single plank all the time



SOUNDPROOFING

EVA and IXPE back padding enhances sound absorption and create a smooth walking experience.



NO FORMALDEHYDE

The layers of the floor are bonded together using advanced heat sealing technology - no glue is used.



NO WARPING AND NO SHRINKING

The flooring is not affected by temperature variations. Avoiding the problem of warping and shrinking.



"Every touch, every footstep on SPC flooring by NEO FLOOR will be a precious moment, the most perfect and wonderful experience!"



FLAME RETARDANT

The flooring meets European fireproof standards. No fire spread.



HIGH IMPACT RESISTANT

The flooring can withstand impacts up to 200kg/cm² due to the solid, hard core layer with density of 2,000kg/m³.



NO TERMITES, MOLD

SPC flooring is wood-free, the perfect solution to eliminate termites and moldings.



100% WATERPROOF

Waterproof due to the integration of CaCO₃ powder with virgin PVC plastic.



ANTI-SLIP, ANTI-SCRATCH

The wear layer plays the crucial role of creating the surface effect, resisting scratches, wearing and slipping.



EASY INSTALLATION

The world's best Unilin and I4F patented locking technology make floor installation super easy, fast and aesthetically pleasing.



Wood Grains





Charred Oak



Country White Oak



Modena Oak



Asiana Exoctica



Moon Rock



Urban Oak



English Oak



Woodland Oak



Cliff Oak



Simpleton Oak



American Red Oak



Canadian Red Oak



Dawn Oak



Florentine Oak



Fresh cut Oak







Golden Oak



Offshore Mist Oak



Wheat Walnut



Honey Maple Oak



Puritan Pine



Indian Red Oak

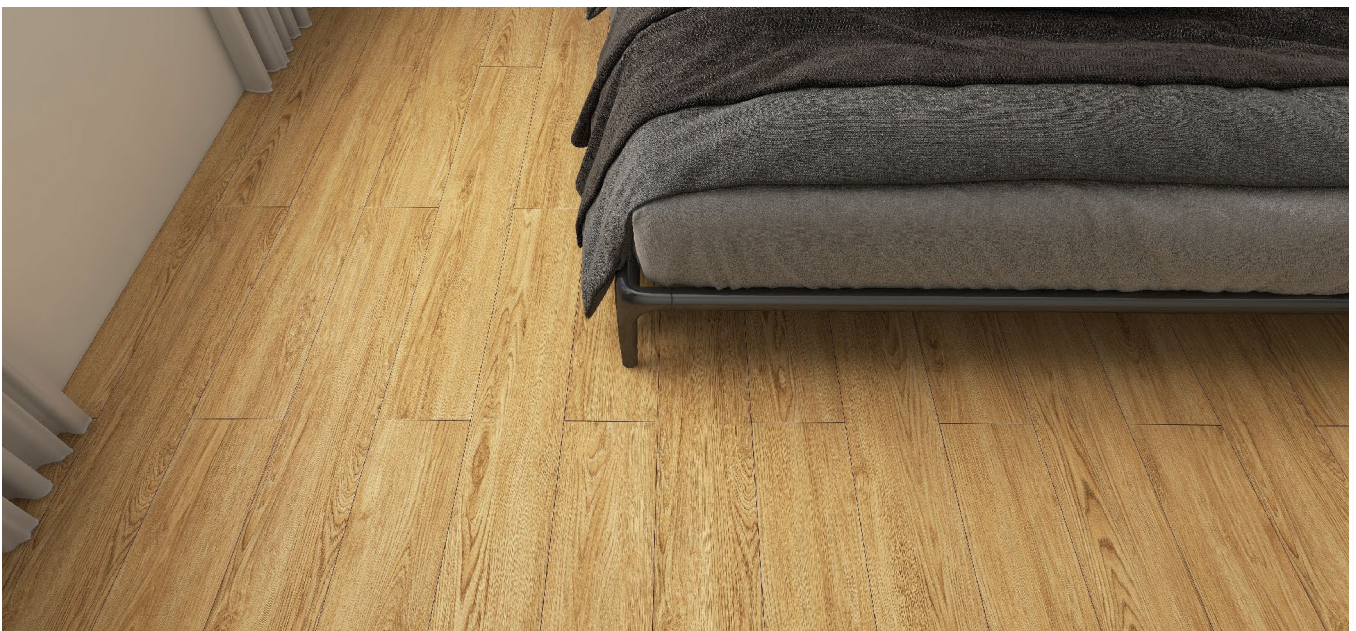



Stone Patterns



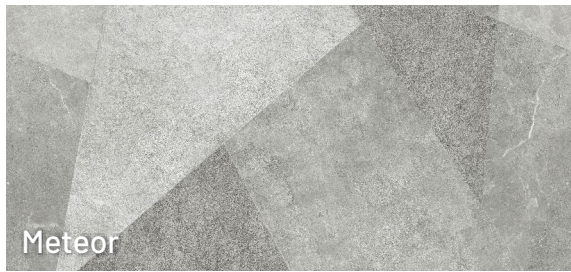

Meteor



Morning Star



Ares White



Moon Light



New Moon



Mercury Gray



Stone Patterns



CAELUS



CRONUS

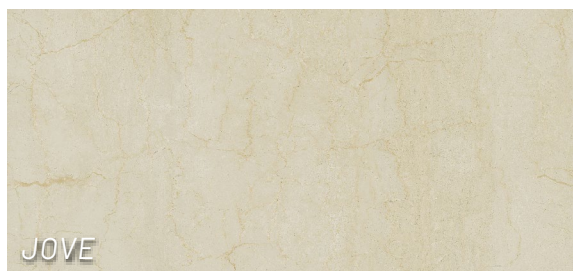

JOVE



VENUS



More than just
SPC flooring

ACCESSORIES

In addition to the SPC flooring, we also produce trims and molding accessories in-house. These are indispensable accessories when constructing and finishing the interior; they cover the expansion gaps for the floor and, at the same time, help to increase the aesthetics, creating a delicate, artistic, and harmonious architectural space. Due to the production of SPC flooring and accessories under one roof, we guarantee color consistency amongst all products.

MATERIALS

Our accessories come in two different materials: SPC and foam to suit every need.

	INGREDIENTS	ADVANTAGE
SPC	PVC resin, CaCO ₃ powder, additives (as SPC flooring)	Tough but flexible enough to use many installation methods (glue, nail or U - track), light weight

FOAM

PVC resin, CaCO₃ powder, foaming agent, additives

Softer than SPC but easy to install. little bit lighter than SPC materials.

**100% virgin material, user health - friendly*

ACCESSORIES STRUCTURE

Wear Layer:

Anti-scratch prevents UV rays from fading

Film layer:

Print 4K graphics for true-to-life looks and colors

SPC Core:

The main ingredient is virgin PVC and stone powder

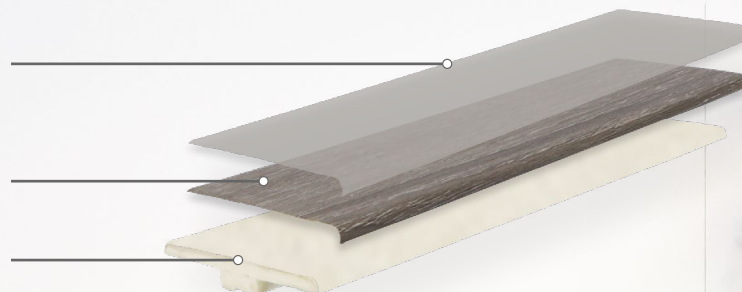







CERTIFICATES:





MOLDINGS

*Available in same colors as regular SPC planks and tiles

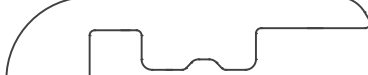
 <p>T-molding SPC</p>	 <p>2400 x 45 x 6</p>
 <p>T-molding Foam</p>	 <p>2400 x 45 x 7</p>
 <p>End cap SPC</p>	 <p>2400 x 35 x 8</p>
 <p>End cap Foam</p>	 <p>2400 x 35 x 9</p>

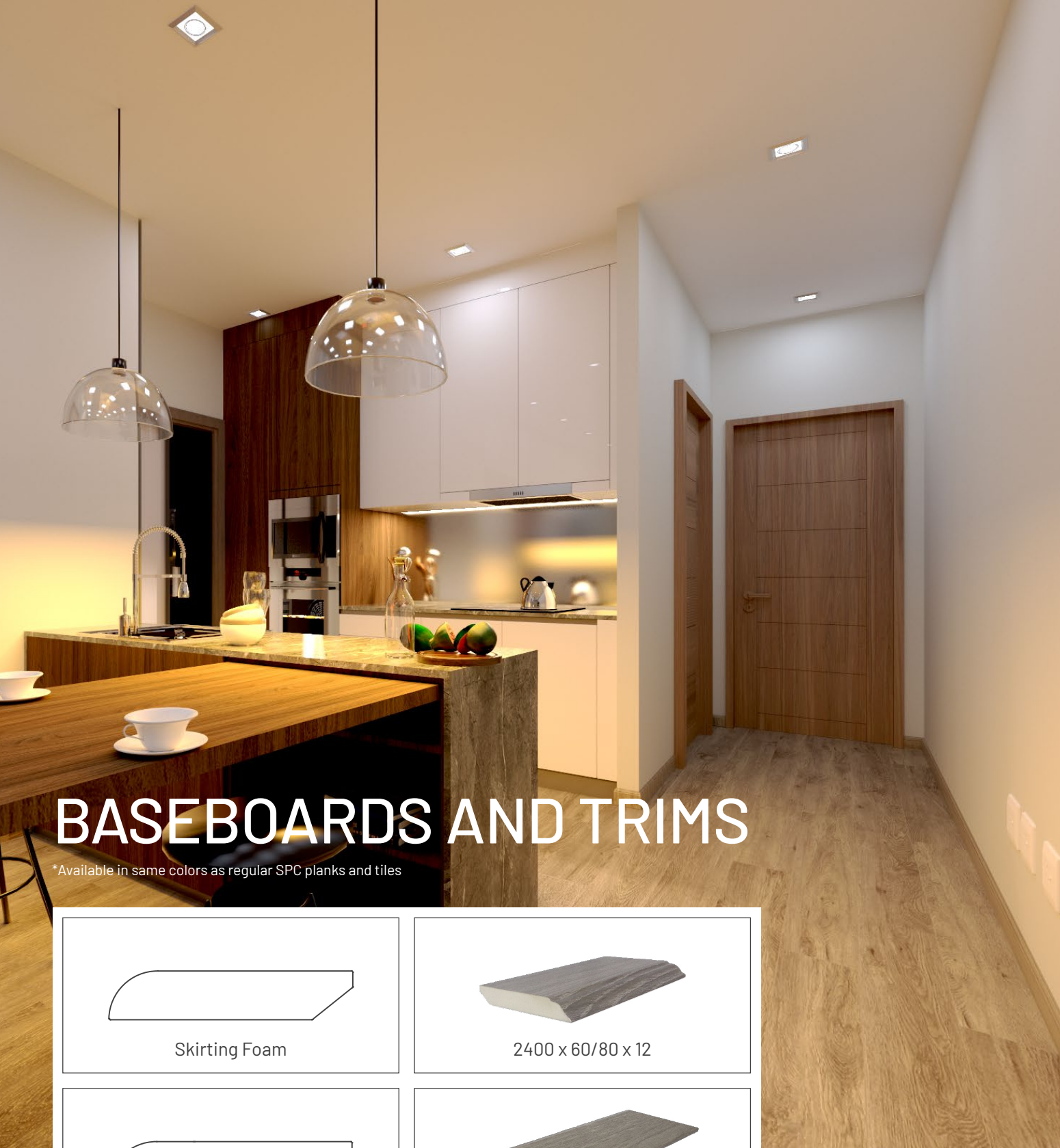

BASEBOARDS AND TRIMS

*Available in same colors as regular SPC planks and tiles



Skirting Foam



2400 x 60/80 x 12

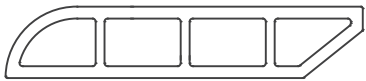

Skirting SPC



2400 x 60/80 x 12



Inside corner molding Foam



2400 x 28 x 15

BASEBOARDS AND TRIMS

*Available in same colors as regular SPC planks and tiles

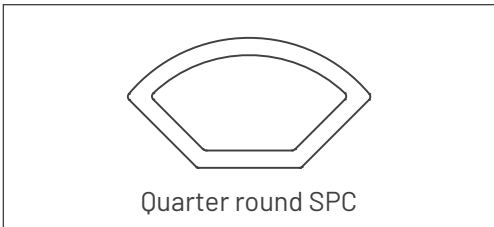
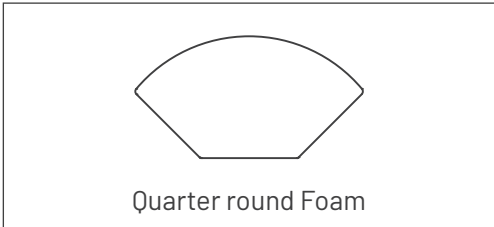
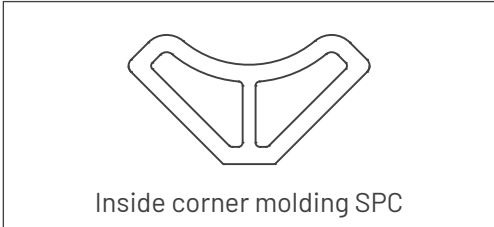



STAIR TREAD

*Available in same colors as regular SPC planks and tiles



Stair tread



22x300x2200 - 22x300x2500

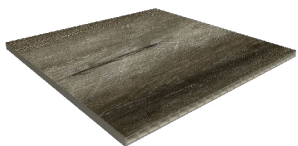

Stair riser



10x200x2200 - 10x200x2500



Stairnose

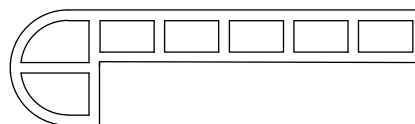

80x22x3000



STAIRNOSE

*Available in same colors as regular SPC planks and tiles



Stair Nose - Flush Foam

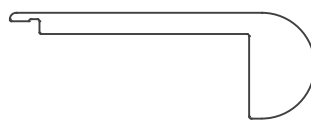

2400 x113 x 25



SPC Stair Nose-Overlap

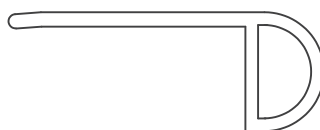

2400 x 56 x 26



NEO FLOOR JOINT STOCK COMPANY
neofloor.com.vn

- **Factory No. 1:** Lot CN 4.1 MP Dinh Vu Industrial Park, Dinh Vu - Cat Hai Economic Zone, Dong Hai 2 Ward, Hai An District, Hai Phong City, Vietnam.
- **Factory No. 2:** Lot CN 4.3 MP Dinh Vu Industrial Park, Dinh Vu - Cat Hai Economic Zone, Dong Hai 2 Ward, Hai An District, Hai Phong City, Vietnam.
- **Office:** No. 4/N09, Huynh Van Nghe Str., Phuc Dong Wd., Long Bien Dist., Hanoi, Vietnam

Hotline: (+84)911.185.096
Website: neofloor.com.vn

